



INSA Trading GMBH

Instruction Manual

Manual Powdercoating Unit Type 5100



This manual is supplied by INSA Trading GmbH, Switzerland



TELEPHONE 214-477-1344

FAX 972-317-6889

PO BOX 294488, LEWISVILLE, TX 75029

www.eicgroupusa.com

Table of Contents

1 Foreword	4
2 Version Information	4
3 Safety-regulations concerning Electrostatic Powder Coating	5
4 Components of the System	7
4.1 Range of delivery	8
5 The Manual Gun Type MG801	9
5.1 Introduction	9
5.2 Detailed instructions	9
6 Recommended voltage settings for typical applications	10
7 The Injector	11
8 The Control Unit Type 5100	12
8.1 The front view of the panel	13
8.2 Different coating modes	15
8.3 Rear view of the control panel	16
9 Unit with the powder hopper	18
9.1 Pneumatic linkup with the hopper.....	20
9.2 Assembly	21
10 Unit with the vibrator table	22
10.1 Pneumatic Linkup with the vibrator table	24
10.2 Assembly	25
11 Adjustment of the coating parameters	26
11.1 Setting of the powder quantity	26
11.2 Selection of the coating mode	27
12 Colour change	29
13 Maintenance	30
13.1 Generalities	30
13.2 Daily Check.....	30
13.3 Weekly check	31
14 Troubleshooting	32
15 Technical Specifications	34
16 Schematic Technical Drawings	35
16.1 Pneumatic Drawer 5200	35
16.2 Electrical Schema Drawer 5200.....	36
16.3 Electronic Control Board ECB110.....	37
17 Parts Listing	38
17.1 Injector	38
17.2 Control Drawer front view	40
17.3 Control Drawer rear view.....	41
17.4 Control Drawer internal view.....	42
17.5 Hopper Unit.....	43
17.6 BoxVibratorUnit.....	453

Illustration Index

Range of delivery of the box vibrator system.....	8
Range of delivery of the hopper system	8
Working of an injector	11
The front panel of the 5100 Series.....	13
Rear view of the control panel type 5100	16
Scheme of a unit with a powder hopper.....	18
Pneumatic connection with the hopper	20
Scheme of a box vibrator unit.....	22
Pneumatic Linkup with the vibrator table.....	24
Setting the powder quantity	26
The different coating modes	27
Electrode holder position at gun reassembly	30
Pneumatic schema Drawer 5200.....	35
Electrical schematic Drawer Type 5200.....	36
Schma ECB 110.....	37
Parts for the injector.....	38
5100 Control Drawer front view	40
5100 Drawer rear view	41
5100 Series Internal View.....	42
Scheme of a hopper unit	43
Schema of a box vibrator unit.....	453

1 Foreword

Thank you for purchasing an INSA Smartcoat System. It is a very efficient system and offers many features to help you apply powder to the most difficult parts. In order to receive the most from your equipment, please take a moment to become acquainted with the different functions, as described in this manual.

Please note that INSA Trading GMBH or its representative can take no responsibility if the equipment is used outside its specification, or for uses other than those described in this manual.

2 Version Information

Version of the document	2
Date of last modification	2003-07-16

3 Safety-regulations concerning Electrostatic Powder Coating

1. The equipment can be dangerous when not used in accordance with the requirements of the following standards:
 - ∞ EN 50 050 (resp. VDE 0745 chapter 100)
 - ∞ EN 50 053 (resp. VDE 0745 chapter 102)
 - ∞ Instructions for electrostatic powder coating ZH 1/444

2. All electrostatically conductive parts within a reach of 5 m from the spray area have to be earthed.

3. The floor of the room containing the spray area has to be electrostatically conductive.

4. The personnel should wear shoes with electrostatically conductive soles.

5. The personnel must handle the gun either with bare hands or with electrostatically conductive gloves.

6. The grounding wire (green/yellow) has to be connected with the grounding screw of the electrostatic manual powder coating unit.

7. The ground wire must have a solid metallic connection to your ground used with the booth, the recovery system and the conveyor chain as well as the objects to be coated.

8. The electric cables as well as the powder hoses leading to the gun have to be handled in such a way that they are protected against mechanical damage.
9. Only after the recovery system has been put into operation can the powdercoating unit be switched on.
10. Electric wires as well as powder hoses have to be checked and cleaned at least daily.
11. The grounding of all the electrostatically conductive parts and equipment within the reach of 5 m from the spray area should be checked at least once a week.
12. The control panel must be switched off when cleaning the gun or when changing nozzles or extensions.

4 Components of the System

A Series 5100 System consists of two separate components, which are both described in this documentation

- A Manual Powdercoating Gun TypeMG801
- A control drawer type 5100 (either with a hopper, with a vibraton table or with no accessories, as a 'Powderset')

Please familiarize yourself with the System before use.

a. Range of delivery

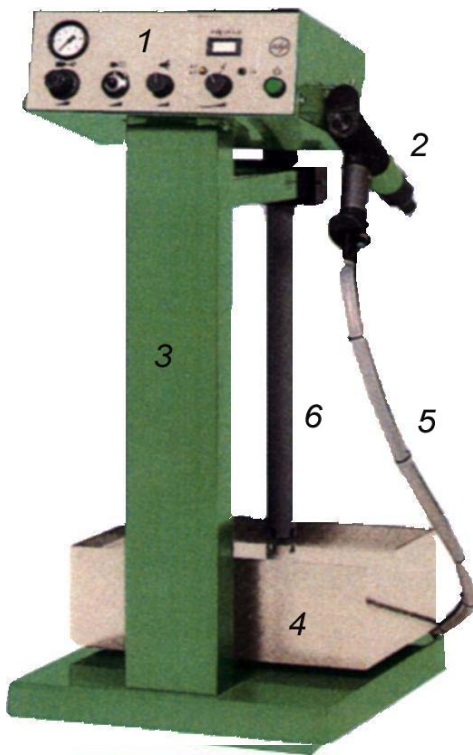

Illustration 1 Range of delivery of the box vibrator system

<i>Position</i>	<i>Box vibrator (Ill. 1)</i>	<i>Hopper (Illustration2)</i>
1	Control Panel Type 5100	
2	Manual Gun Series MG801	
3	Stand on Rollers	
4	Vibration table	Powder hopper
5	Hoses and Cables	
6	Injector with suction tube	

The Powderset consists of Positions 1,2 and 6

5 The Manual Gun Type MG801

a. Introduction

The manual powder gun MG801 with the integrated high voltage generator is designed to apply electrostatically chargeable powder to grounded work-pieces. The gun is designed with state of the art of technology. The parts are assembled in a simple manner which guarantees easy maintenance and repair. The guns produce high voltage and it is therefore absolutely necessary to read the instruction manual carefully before starting to operate.

The guns are built in accordance with the CE-regulations and in combination with the electronic control board ECB, tested in conformity with the EN-50 050/54 regulation.

Important

As the manual gun MG801 and the electronic control board ECB 110 have been controlled according to the EN 50 050 as components of a configuration, they can only be used in this combination. Any change or manipulation of the components will automatically void the warranty. Use only original spare parts, to maintain the warranty.

b. Detailed instructions

The Operation of the INSA Manual Gun Series 801 is described in detail in the Manual. Manual Guns Types MG801, MG801S, MG850 – for Automatic Gun AG800 refer to the separate manual for detailed instruction on Operation and Maintenance.

6 Recommended voltage settings for typical applications

The adjustment of the voltage can be done at the control drawer type 5100, 5800 or the panel of the 5300 Series 'Suitcase'.

The powder application may vary, and depends on several external factors:

- Type of powder used
- Desired thickness of the powder film
- Range of different workpieces to be coated

The table below may be used as a starting point.

We recommend the following settings for a typical application:

<i>Voltage</i>	<i>Typical Application</i>
100 kV	Large flat parts, filmthickness 60 micron
80 kV	General application
60 kV	Profile coating
50 kV	Application of metallic powder

7 The Injector

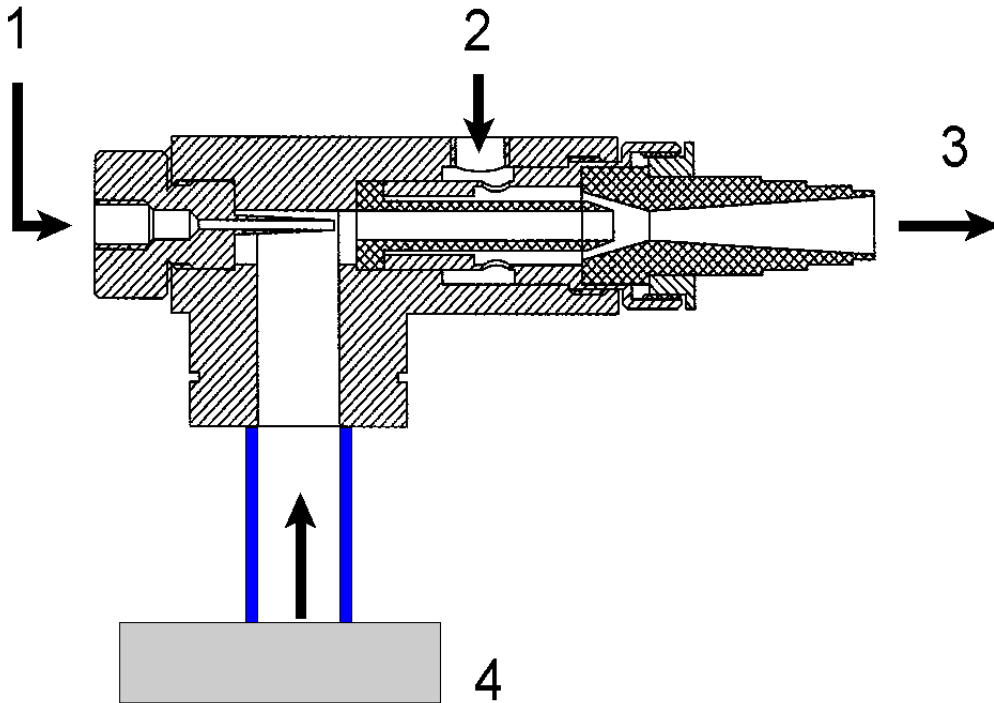

The feeding air (Pos. 1 in Illustration 3) creates an underpressure in the injector chamber. The powder is sucked from the box or the hopper (pos. 4) and is then fed into the powder hose (pos. 3).

It is possible to adjust the air speed with the input regulator and the manometer readout.

When the air speed is too low the system is unstable, and the powder will start pulsating. In that case, the input pressure needs to be increased.

If the powder output is too low, an increase of the input pressure may remedy the situation. Please consult the section 0 on page 26 for further details on adjusting the output.

8 The Control Unit Type 5100

The control Unit Type 5100 is available in three variants, which are identical, feature wise

- œ as a Powderset, Control Unit only
- œ mounted on a stand, with a hopper
- œ mounted on a stand, with a box vibrator, allowing for fast color change

All three varieties share a common set of features, which will be described here. The pictures will be those of the powderset showing only the controller.

a. The front view of the panel

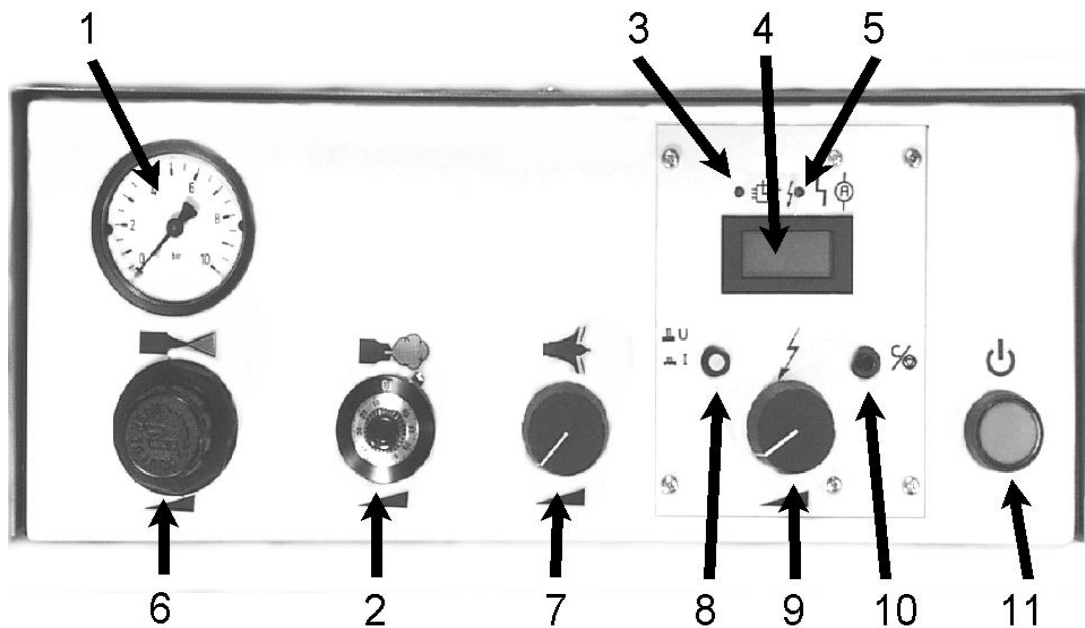

<i>Position in Illustration 4</i>	<i>Description</i>
1	Input pressure readout
2	Powder volume regulator
3	Current Limitation Indicator
4	Voltage Display
5	Signal overvoltage or cable defect
6	Pressure regulatot
7	Deflector cleaning air adjustment knob
8	Coating Mode selector

Instruction Manual INSA Series 5100

<i>Position in Illustration 4</i>	<i>Description</i>
9	Parameter adjustment knob
10	System reset button
11	Main Switch

b. Different coating modes

The Series 5100 Systems feature two different coating Modes, as follows:

<i>Coating Mode</i>	<i>Description</i>
Standard (U)	Offers a standard set of parameters for general puposes and coating faraday areas.
Tribo Mode (I)	Keeps the electric current constant for flat parts and allows for the operation of triboelectric guns with the unit

The modes are selected by button 8 in Illustration 4. They can be adjusted by the knob 9 in the illustration. Button 10 serves as a reset knob.

IMPORTANT NOTICE

If you want to operate tribo guns with the unit, you must leave the unit in tribo mode. Standard mode might damaege your tribo guns

c. Rear view of the control panel

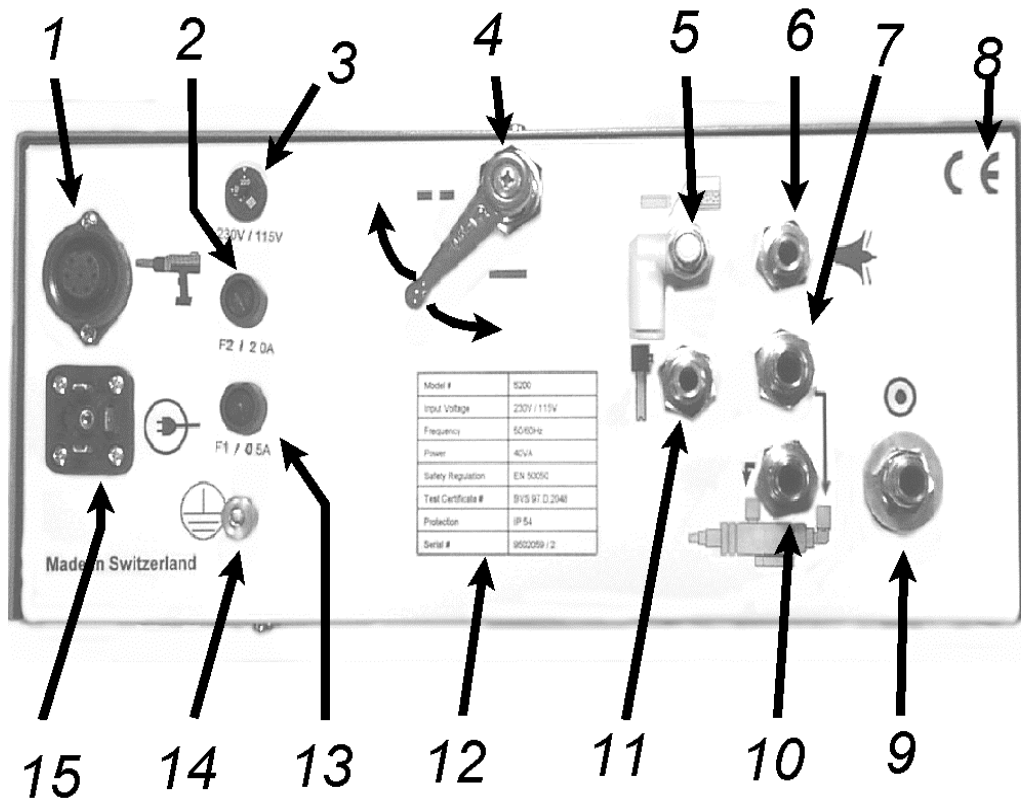

Please refer to the table on the next page

Instruction Manual INSA Series 5100

<i>Position in Illustration 5 on page 15</i>	<i>Description</i>
1	Gun Plug
2	Fuse
3	Voltage Selector 230/115 V
4	Air Selection switch
5	Regulator / Connection for hopper or vibrator table
6	Connector for cleaning air
7	Connection for feeding air
8	CE Symbol
9	Main Air connector
10	Connection for dosage air
11	Connection for pressure regulator
12	Manufacturer Label
13	Fuse
14	Grounding Screw (to powder hopper)
15	Main Power Supply

9 Unit with the powder hopper

This section is dedicated to the unit with a powder hopper. This unit is equipped with a porous fluid plate. Compressed air keeps the powder fluidised. The powder particles are kept suspended in the air. Suction from the injector assembly will transport the powder particles through the powder hose to the gun.

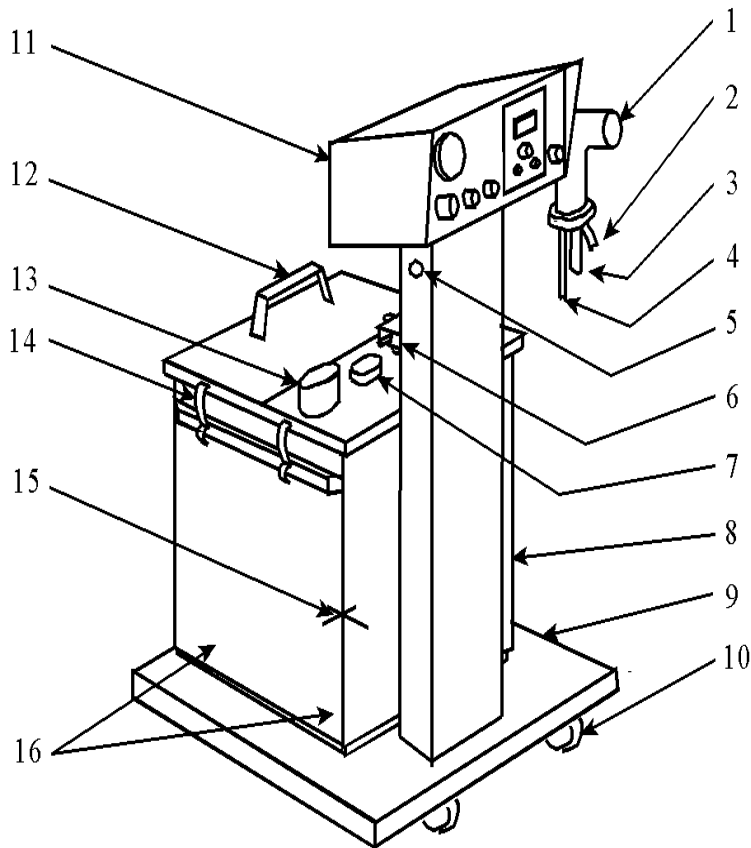

Instruction Manual INSA Series 5100

<i>Position in illustration 6</i>	<i>Description</i>
1	Powder Gun
2	Air Connection for deflector cleaning
3	Powder hose
4	Electric Cable
5	Air hose for fluidisation air
6	Injector
7	Connection for (optional) additional injector
8	Powder hopper
9	Stand on rollers
10	Roller
11	Control Panel
12	Handle
13	Airing Connection
14	Lockers
15	Pneumatic Quick connector
16	Positioning bolt

a. Pneumatic linkup with the hopper

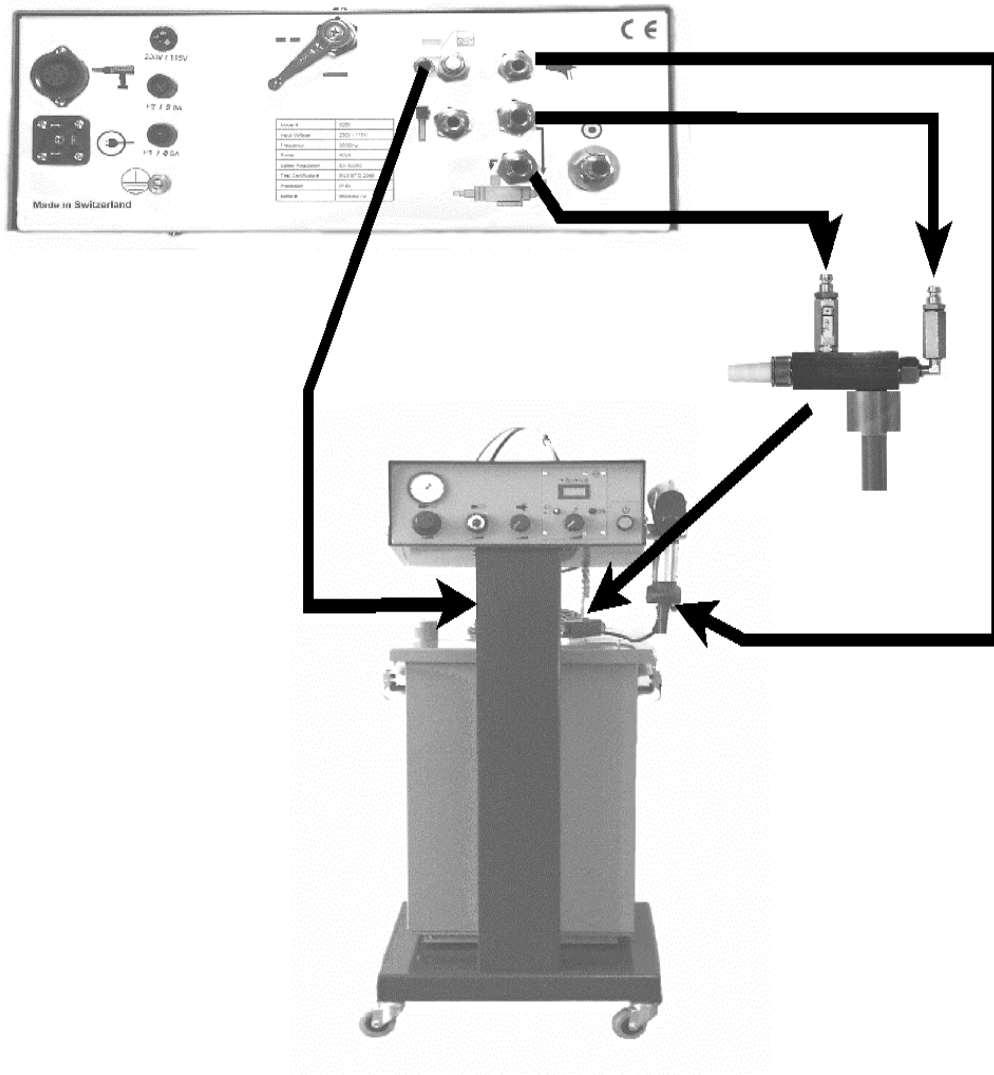

b. Assembly

Assemble as follows:

1. Put the powder hopper (Pos 8 in Illustration 9 on page 23) onto the stand with the quick disconnect and guide legs in appropriate holes on stand base(pos 9)
2. Connect injector, gun and powder hopper according to the wiring diagram
3. Connect the grounding wire (on the backside of the drawer) to the ground screw on top of the powder hopper
4. Connect the gun plug with the control drawer
5. Install the injector suction tube on the hopper cover
6. Connect the main power supply with the drawer and fix it in position
7. Connect the cable with the main supply
8. Switch on the unit with the main switch
9. Turn the HT-Knob to the minimum
10. Set the input pressure to 3 bar
11. Hold the gun into the booth and pull the trigger
12. Adjust the fluid air supply so that the powder is properly fluidised.
13. Turn the powder quantity regulator to pos. 10
14. Adjust the air pressure with the regulator until the powder flow is continuous (you don't want a pulsing powder supply). If the powder output is too low you need to readjust the output pressure. Normal operational pressure is between 1 and 6 bars.
15. Adjust the output voltage
16. Adjust the muzzle (cleaning) air so the front of the deflector stays clean. If a flat spray muzzle is used, adjust the air flow so that you get a soft cloud.
17. Set the position of handle 4 in Illustration 5 on page 15 to continuous fluidization only during the operation of the unit

10 Unit with the vibrator table

This section details the installation of the powdercoating unit with a vibrator table. This unit comes with a vibration table where the box of powder is placed. The powder particles in the powder box are separated by vibration. The powder is fluidized by the fluid plate at the bottom of the suction tube. Suction from the injector will ensure a gentle powder flow from the box of powder through the suction tube to the gun.

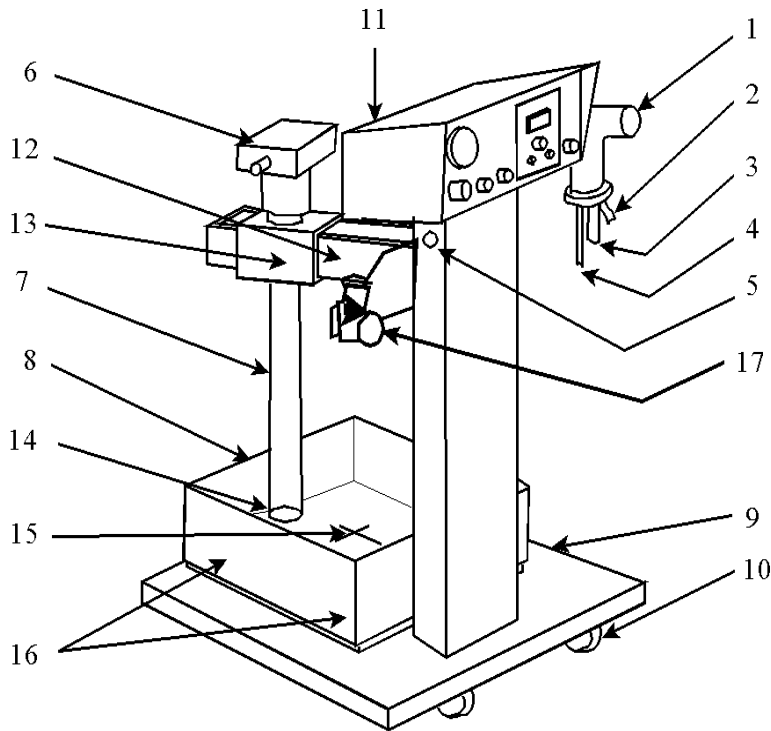

Please refer to the table on the next page.

Instruction Manual INSA Series 5100

<i>Position in Illustration 8</i>	<i>Description</i>
1	Powder gun
2	Connection for deflector cleaning air
3	Connection for powder hose
4	Electric Cables
5	Air hose for vibrator table
6	Injector
7	Suction Tube
8	Vibration Table
9	Stand
10	Roller
11	Control Drawer
12	Movable Arm
13	Guide for suction tube
14	Fluid plate in suction tube
15	Pneumatic Quick connector
16	Positioning bolt
17	Pressure regulator for suction tube

a. Pneumatic Linkup with the vibrator table

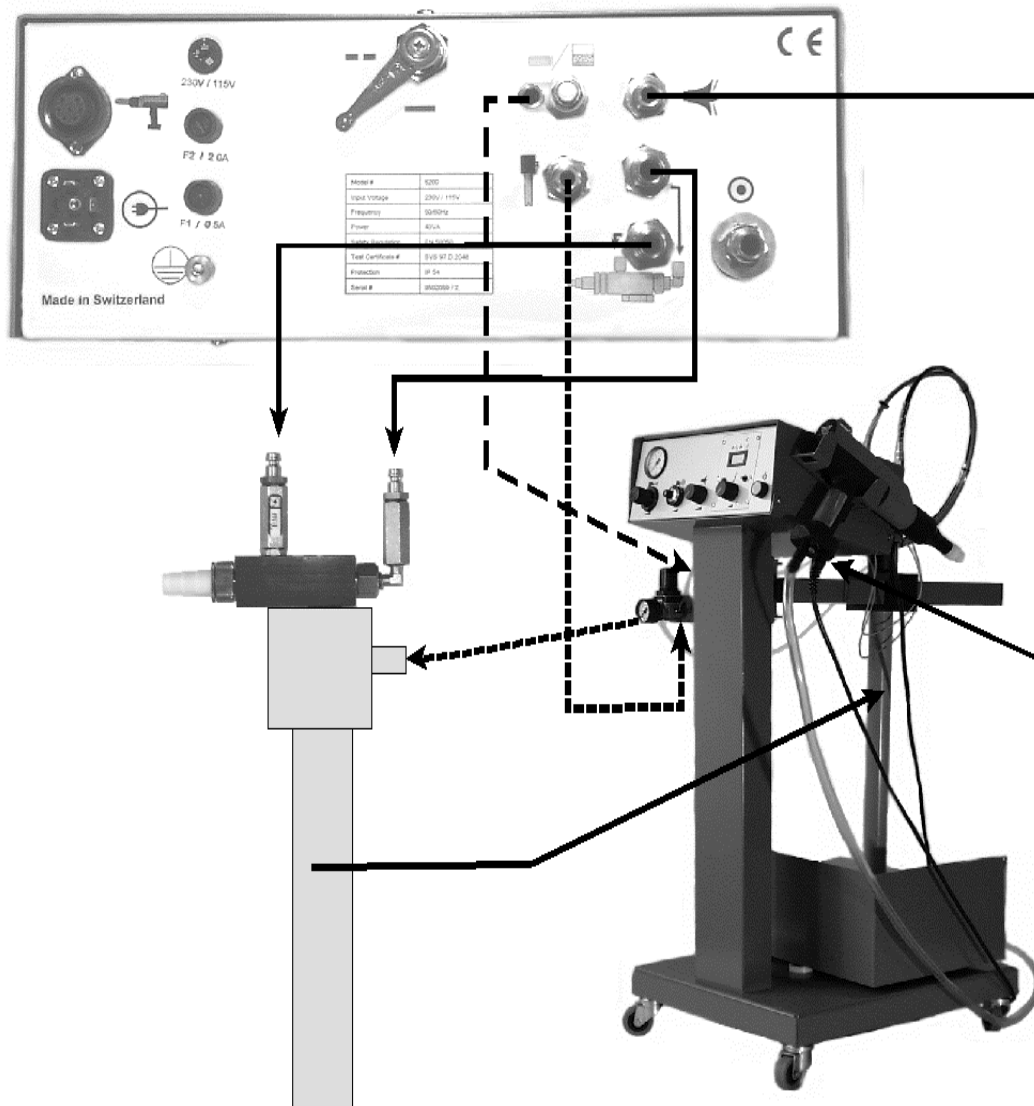

b. Assembly

Assemble as follows:

1. Put the vibrator table (Pos 8 in Illustration8 on page 21) onto the stand with the quick disconnect and guide legs in appropriate holes on stand base(pos 9)
2. Connect injector, gun and powder hopper according to the wiring diagram
3. Connect the grounding wire (on the backside of the drawer) to the ground position on top of the injector block
4. Connect the gun plug with the control drawer
5. Install the injector and the injector suction tube
6. Connect the main power supply to the drawer and fix it in position
7. Connect the cable with the main power supply
8. Plug in the main air supply
9. Put the powder box onto the vibrator table
10. Switch on the unit with the main switch
11. Turn the HT-Knob to the minimum
12. Set the input pressure to 3 bar
13. Hold the gun into the booth and pull the trigger
14. Adjust the fluid air supply so that the powder has proper vibration and fluidization is appropriate at the end of the suction tube
15. Turn the powder quantity regulator to pos. 10
16. Adjust the air pressure with the regulator until the powder flow is continuous (you don't want a pulsing powder supply). If the powder output is too low you need to readjust the output pressure. Normal operational pressure is between 1 and 6 bars.
17. The powder quantity can be adjusted with the powder quantity knob and/or regulator assembly
18. Adjust the output voltage
19. Adjust the muzzle air so the front of the deflector stays clean. If a flat spray muzzle is used, adjust the air flow so that you get a soft cloud.
20. Adjust the air pressure of the vibrator table. Use the heaviest powder box and adjust vibration as low as possible.

11 Adjustment of the coating parameters

This chapter will detail the adjustment of the different coating parameters.

a. Setting of the powder quantity

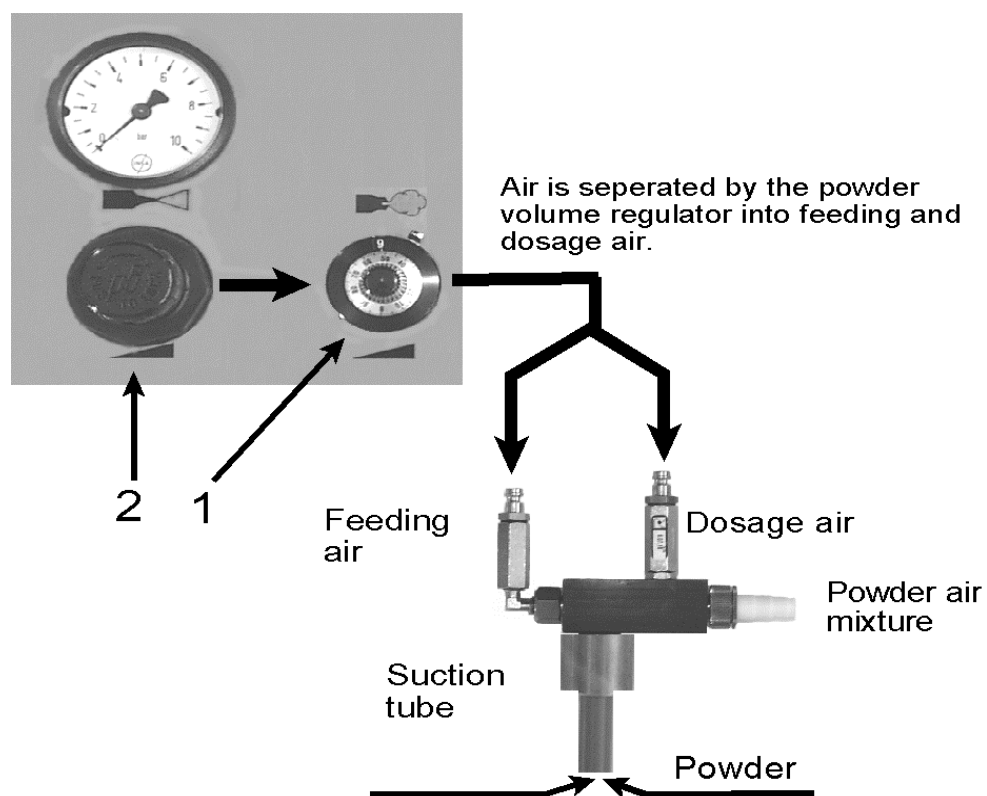

First adjust the pressure regulator (pos. 2 in illustration 10) to between 2.5 and 3.5 bar. The powder volume regulator (pos. 1) should be on position 10. It is necessary to avoid a pulsing powder cloud by adjusting the powder volume regulator to a lower position which put air into the dosing side of the injector. When you have a smooth flow of slow moving powder lock the setting at the powder volume regulator. Powder output can now be adjusted with the pressure regulator (pos. 2), for more powder adjust to a higher setting, for less to a lower setting. The percentage of air to the injector Feeding Air and Dosage Air will remain the same.

b. Selection of the coating mode

The Series 5100 Systems feature two different coating Modes, as follows:

<i>Coating Mode</i>	<i>Description</i>
Standard (U)	Offers a standard set of parameters for general purposes and coating faraday areas
Tribo Mode (I)	Keeps the electric current constant for flat parts and allows for the operation of triboelectric guns with the unit

The modes are selected by button 8 in Illustration 4. They can be adjusted by the knob 9 in the illustration. Button 10 serves as a reset knob.

IMPORTANT NOTICE

If you want to operate tribo guns with the unit, you must leave the unit in tribo mode. Standard mode might damage your tribo guns

Standard Mode – Constant current

This mode keeps the current constant as long as possible, when you move the gun closer to the object the voltage will drop. Use this mode if you need to coat large surfaces uniformly and faraday areas.

Tribo mode – Constant Voltage

This mode will act on the voltage, keeping it constant as long as possible when the gun is moved closer to the object to be coated. This will prevent the generation of too many free ions, and therefore reduce the 'orange peel' effect dramatically.

Use this mode if you need to coat flat parts.

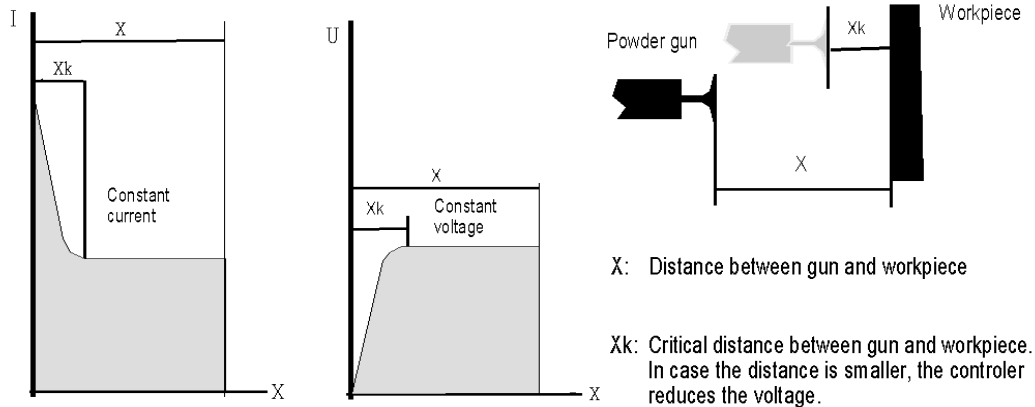

12 Colour change

To change colours, operate as outlined below:

1. Switch off the unit (Air/Voltage)
2. Disconnect the pneumatic hoses from the injector (red/blue)
3. Clean the powder hose with compressed air
4. Take off the muzzle from gun and clean it and the interior tubes and gun exterior with compressed air
5. Take off the injector and clean it with compressed air (it may be necessary to disassemble the injector and clean individual parts)
6. Clean the rubber sealing and the vent air outlet on hopper lid
7. Empty the powder hopper and clean it with compressed air
8. Put the injector back in place
9. Assemble the gun muzzle
10. Fill in powder of the new colour
11. Reinstall connections
12. Switch unit back on (Air/Voltage)

13 Maintenance

a. Generalities

A regular maintenance of the system is necessary in order to guarantee uniform results. It will also prolong the life of the components of your system.

**Please take note of the following points before doing
any maintenance work**

- Before disassembling the unit or gun, the control drawer must be switched off.
- The gun plug must be disconnected.
- The compressed air used for cleaning must be free of oil and water.
- It will only be necessary to take off the muzzle of the gun. Further disassembly is unnecessary, the balance of the gun contains no user-serviceable parts.

b. Daily Check

- ☞ Clean the injector
- ☞ Change the insert Sleeve if necessary (wearing part)
- ☞ Clean the gun with compressed air

Please Note

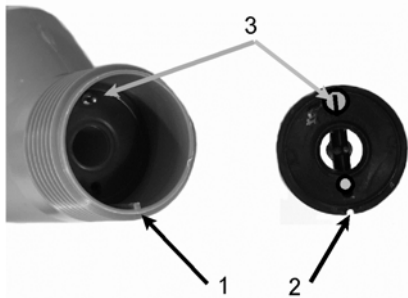

Illustration 12 Electrode holder position at gun reassembly

- When reassembling the electrode holder and the muzzle, it has to be ascertained that the groove in the electrode holder (pos.2) and the muzzle correspond with the guide (pos.1) in the gun.
- The contact hole in the electrode holder must be free of powder to assure a good electrical contact. This prolongs the lifetime of the electrode holder and gives the best coating performance.

c. Weekly check

- œ Clean the powder hoses
- œ disassemble and clean the gun
- œ examine muzzle and deflector of the gun, replace if necessary (wearing parts)
- œ disassemble the injector completely and clean all parts. Change the insert sleeve if necessary (wearing part)

Please Note

Other than the muzzle assembly, the gun contains no user servicable parts.

14 Troubleshooting

Caution

Before opening the casing, switch off the electrical voltage and disconnect the electric cable.

<i>Failure</i>	<i>Causes of failure</i>	<i>How to fix them</i>
No voltage supply	<ul style="list-style-type: none"> - main supply not connected - broken cable - input fuse defective 	<ul style="list-style-type: none"> - connect it -replace it -replace it
No light on main switch	<ul style="list-style-type: none"> - lamp defect 	<ul style="list-style-type: none"> - replace it
No high tension	<ul style="list-style-type: none"> - ECB 100 defect -cascade defect -gun switch defect -cable broken 	<ul style="list-style-type: none"> -replace it -replace it -replace it -replace it
Powder poorly charged	<ul style="list-style-type: none"> - no high tension - electrode covered with powder -parts not grounded - faulty cascade 	<ul style="list-style-type: none"> - follow above mentioned advice - clean it - connect part with the ground - replace it

Instruction Manual INSA Series 5100

<i>Failure</i>	<i>Causes of failure</i>	<i>How to fix them</i>
No powder flow	<ul style="list-style-type: none"> - examine the input pressure - defect magnetic valve - ECB 110 defect 	<ul style="list-style-type: none"> - Replace it - replace it
Insufficient coating of the corners	<ul style="list-style-type: none"> - Powder output speed too high - voltage too high 	<ul style="list-style-type: none"> - reduce air pressure - reduce it

15 Technical Specifications

<i>Control Panel Series 5200</i>	
Type	5200
Input voltage	115V or 230V, selectable
Frequency	50 – 60 Hz
Temperature Range	+10 C to +42 C
Test Standard	EN 50 050
Test License No	BVS 97.D.2048
<i>Pneumatic Data</i>	
Minimal Input Pressure	3 bar
Maximal Input Pressure	10 bar
Maximal water content in compressed air	1.3g / m ³
Maximal oil content in compressed air	0.1mg/kg
Maximal air consumption	9m ³ /h
<i>Dimensions</i>	
Length	420mm
Width	495mm
Height	920mm
Weight	Approximately 42 kg

b. Electrical Schema Drawer 5200

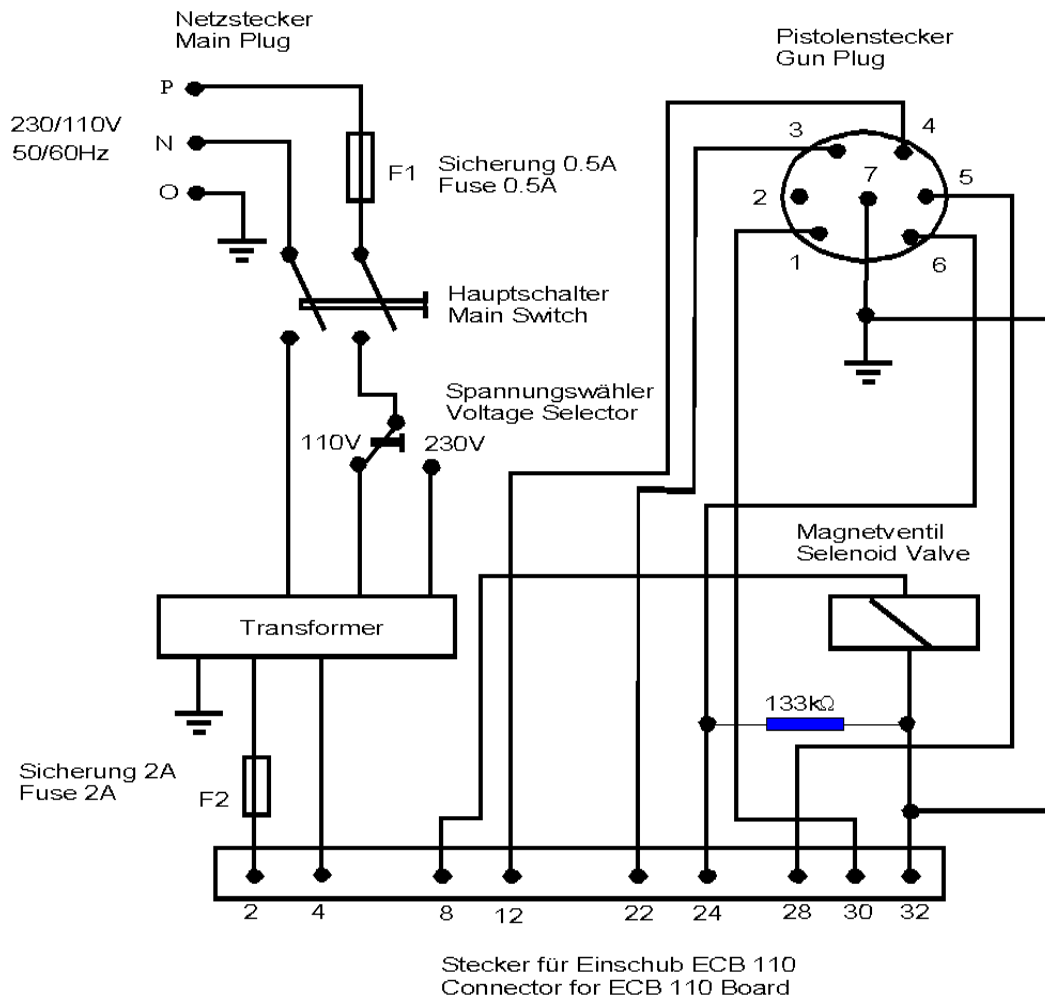

c. Electronic Control Board ECB110

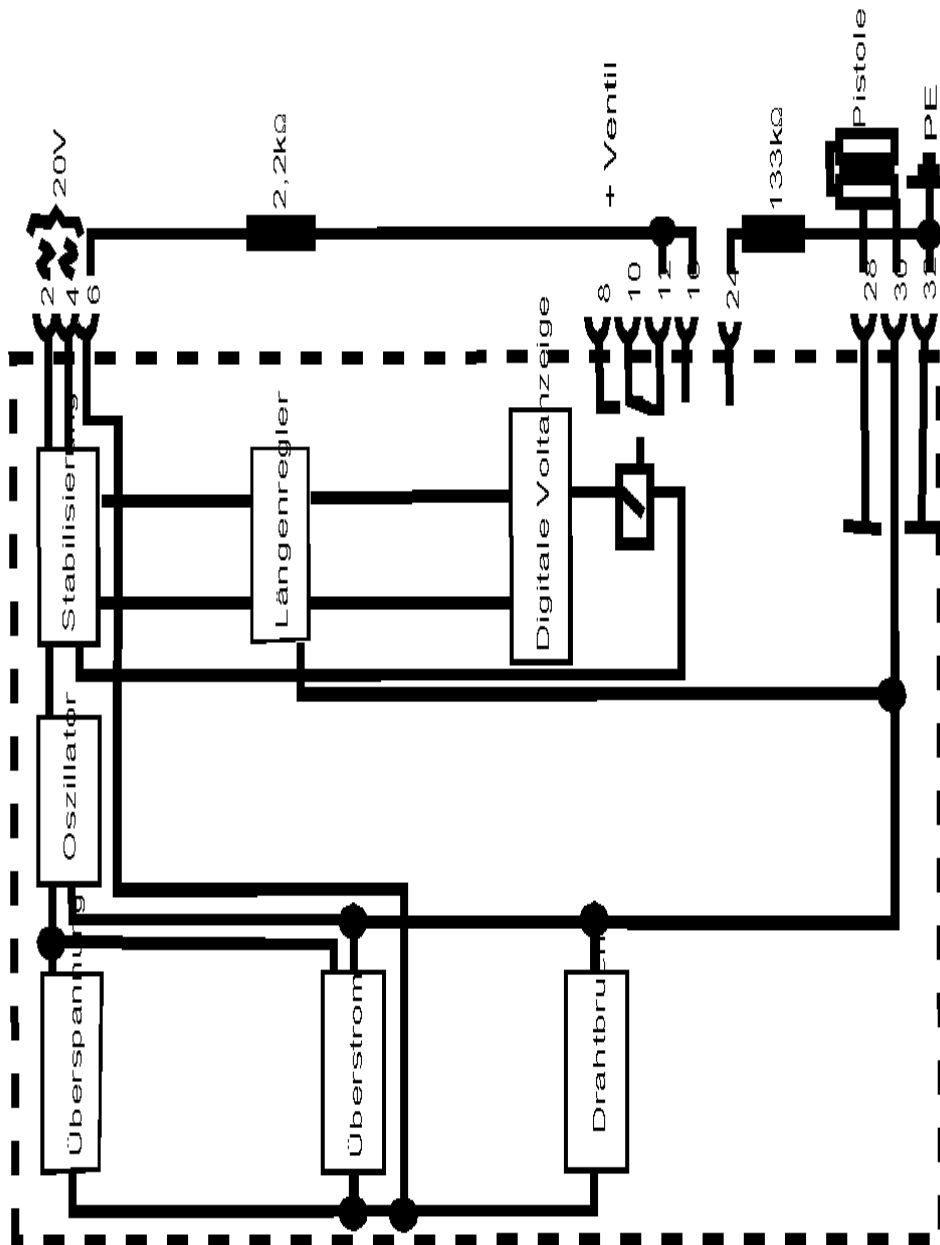

17 Parts Listing

a. Injector

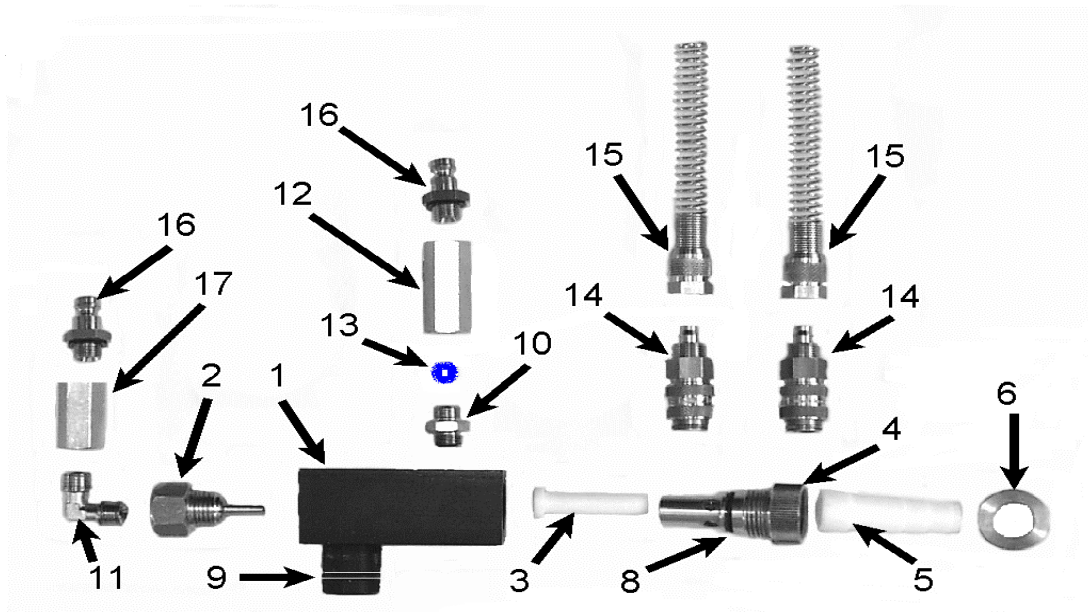

Instruction Manual INSA Series 5100

<i>Position in Illustration 16</i>	<i>Order No.</i>	<i>Description</i>
1	300.001.01	Injector Block
2	<i>300.002.01</i>	<i>Nozzle 1.8mm</i>
	<i>300.002.02</i>	<i>Nozzle 1.5mm</i>
	<i>300.002.03</i>	<i>Nozzle 1.3mm</i>
3	<i>300.003.01</i>	<i>Teflon Sleeve 5mm</i>
	<i>300.003.02</i>	<i>Teflon Sleeve 4.5mm</i>
4	300.004.01	Powder Socket
5	300.005.01	Hose Holder
6	300.006.01	Connection Nut
7	300.007.01	Suction Tube, L=520
	300.007.02	Suction Tube L=560
	300.007.02	Suction Tube, L=625
8	300.008.01	O-Ring
9	300.009.01	O-Ring
10		
11	300.011.01	Angle Screw Joint 1/8"
12	300.012.01	Check Valve
13	200.071.01	Reduction 1.8mm
	200.071.02	Reduction 1.5mm
	200.071.03	Reduction 1.3mm
14	300.014.01	Coupling Socket
15	300.015.01	Screw cap with buckling protection
16	300.016.01	Coupling socket
17	300.017.01	Spacer

Wearable parts are printed in *italic typeface*

b. Control Drawer front view

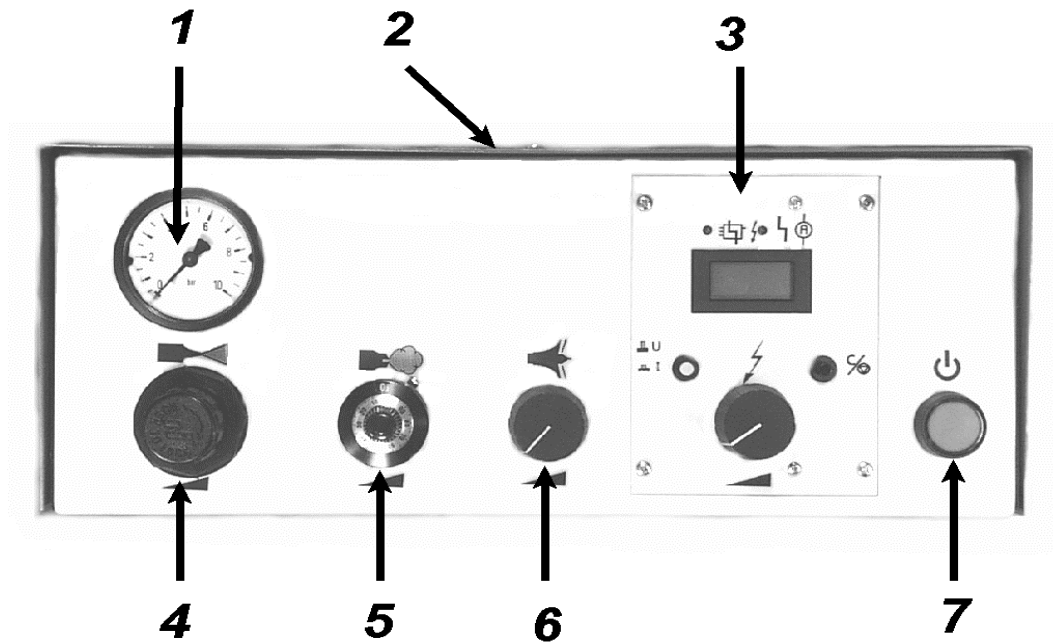

<i>Position in Illustration 17</i>	<i>Order No.</i>	<i>Description</i>
1	600.010.01	Manometer 10 bar
2	600.032.01	Cover
3	100.003.04	ECB Card
4	600.007.01	Pressure regulator, big
5	600.020.01	Head foir FD Controller
6	600.008.01	Pressure regulator, small
7	600.062.01	Main Switch

c. Control Drawer rear view

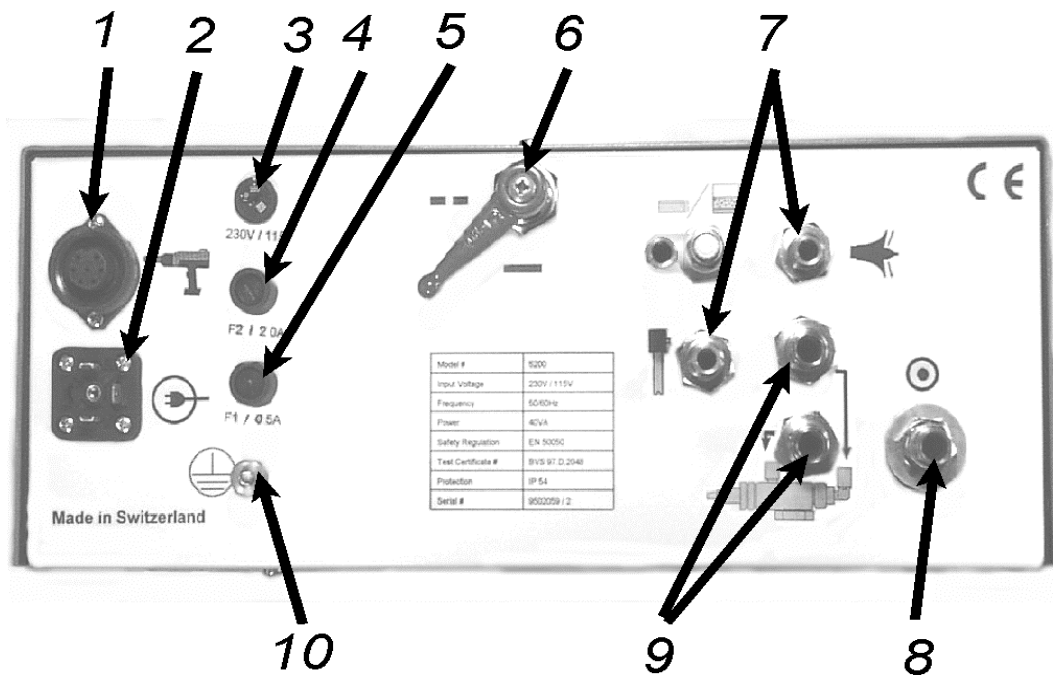

<i>Position in Illustr. 18</i>	<i>Order Nr.</i>	<i>Description</i>
1	100.002.01	Connecting Socket 7 Pole
2	600.052.01	Inline Socket
3	100.018.01	Voltage Switch 230/115V
4	100.016.02	Fuse 2.0 A
5	100.016.01	Fuse 0.5 A
6	200.076.01	Air Feeding Selector
7	600.011.01	Pneumatic Connector
8	600.032.01	Pneumatic Connector
9	600.012.01	Pneumatic Connector
10	500.052.01	Earthing Screw

d. Control Drawer internal view

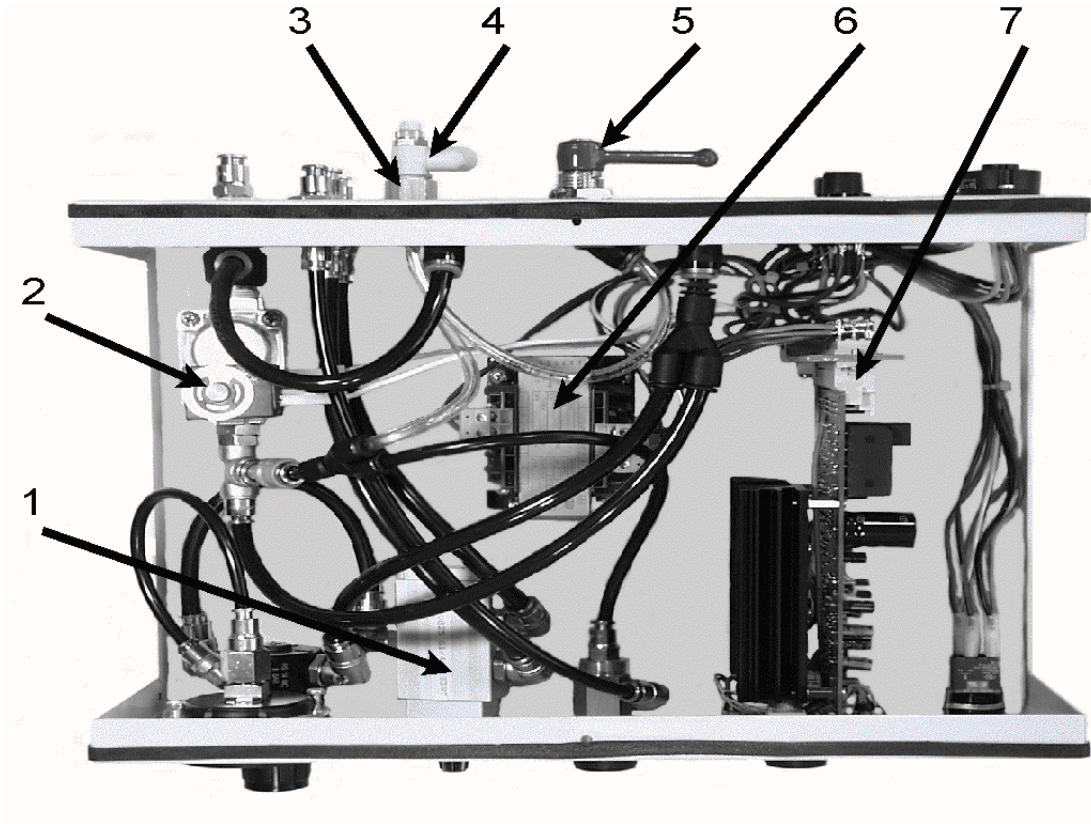

<i>Position in Illustr. 19</i>	<i>Order No</i>	<i>Description</i>
1	100.008.01	FD Regulating Knob
2	600.005.01	Solenoid Valve
3	200.061.01	Connector
4	200.047.03	Needle Valve
5	200.076.01	Selector
6	100.003.04	ECB Card
7	600.035.01	Transformer

e. Hopper Unit

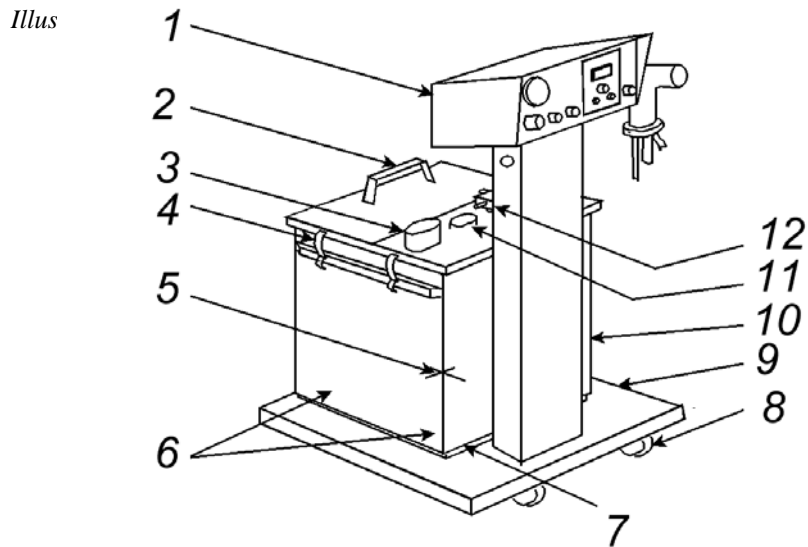

<i>Position in Illustration 20</i>	<i>Order No</i>	<i>Description</i>
1	601.000.01	Drawer Type 5200
2	500.041.01	Handle
3	500.042.01	Protection Plug
4	500.044.01	Tensioning Clamp
5	500.043.01	Quick Coupling
6	500.045.01	Guide Foot
7	500.046.01	Fluid Plate
8	500.040.01	Steering Roller
9	500.002.01	Stand without drawer
10	500.054.01	Powder hopper
11	500.039.01	Protection Plug

Instruction Manual INSA Series 5100

<i>Position in Illustration 20</i>	<i>Order No</i>	<i>Description</i>
12	310.000.03	Injector complete

f. Box Vibrator Unit

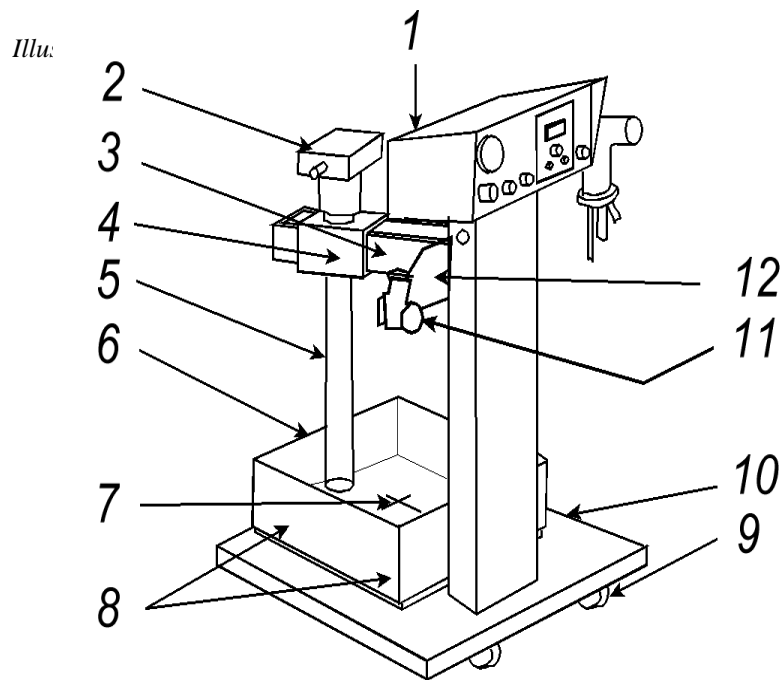

<i>Position in Illustration 21</i>	<i>Order No</i>	<i>Description</i>
1	601.000.01	Drawer Type 5200
2	310.000.03	Injector complete
3	500.041.01	Handle
4	500.042.01	Protection Plug
5	300.016.01	Suction tube for vibrator table, without injector
6	500.007.02	Vibrator Table
7	500.043.01	Quick Coupling
8	500.045.01	Guide Foot
9	500.040.01	Steering Roller

Instruction Manual INSA Series 5100

<i>Position in Illustration 21</i>	<i>Order No</i>	<i>Description</i>
10	500.002.01	Stand without drawer
11	200.043.01	Holer for Pressure Regulator
12	200.074.01	Pressure Regulator